

**PRODUCTION NOTES**

- PRODUCTION ELECTRICIAN TO INSPECT AND DETERMINE BEST MOUNTING METHOD OF ALL LIGHTING POSITIONS.
- All Cables Neat. Discuss Any Areas That Will Be Heavily Trafficked With Walking.
- And Provide Rubber Mats Where Necessary.
- Determine Dimmer Placements With Technical Director.
- Provide Safety Lights Backstage.
- All Trims Measured From Bottom Pipe Of Truss To Venue Floor. Exact Trims To Be Set On Site By Designer.
- Minimize Footprint Of Lighting Positions Where Possible Without Compromising Safety.
- Positions Must Be Very Secure.
- Provide A Generous Amount Of Sandbags To Secure All Floor Mounts Where Possible.
- All Units Have Safety Chain, C-clamps, and Color Frames.
- All Units And Color Frames Are Black.
- All Pipe, Clamps And Other Hardware Are Black.
- Provide Spare Circuits To All Positions.
- Provide Spare Units.
- Provide Spare Lamps For All Lamp Types.
- Exact Placement Of All Floor Units And Set Mounts To Be Determined On Site By Designer.
- Exact Placement Of Set Mounts To Be Determined On Site By Designer.
- Lighting Shop please provide (2) Source 4, B-Size glass gobos holder.

**SPARE REQUIREMENTS.**

Spare Color:  
In addition to the color and scrolls on the hookup, please provide:  
1 Roll of blackwrap  
2 sheets of R100  
2 sheets of R101  
1-sheet of R104  
2-sheets of R107  
2-sheets of R109  
1-sheet of L210  
- Provide lots of extra of everything

Spare Units:  
In addition to spares provided by Production Electrician, please supply the following additional units (full fixture):  
2-Source 4 50"  
2-Source 4 36"  
2-Source 4 26"  
2-Source 4 19"

**Color Changers**  
NIC (No spare)  
DMX 512 Wytron Scrollers  
All on Source 4 Lamps.

FRAME	COLOR
1	NIC
2	L161
3	L166
4	L118
5	L158
6	G245
7	L128
8	R56
9	L119
10	L116
11	L124

**CONTROL**  
(2) House console and is Back Up)  
-Each board with color monitors and most recent software.  
Also provide:  
• Necessary Control Lines with spares as needed  
• 6-disks Formatted For the Whole Hog  
• 2-Little Lite Desk Lamps With 18" neck and Weighted Bases  
• Opto Splitters As Needed

**Followspots**  
Show will use house followspots.

All Spots  
1-L205+L206  
2-L206  
3-L209  
4-R119  
5-L142  
6-L161  
L279 (Tape to front of Unit)

**HAZE**  
• Provide (2) DF50 Hazers with plenty of juice and fans (SR: CH 940; SL: CH 941)  
• EXACT POSITION OF HAZERS TBD ON SITE.  
• PROVIDE PLENTY OF EXTRA CABLE.

**NOTE**  
• Show will use ENTIRE house system.  
• Road Electrician should discuss integration of rental gear and dimmers with house system.

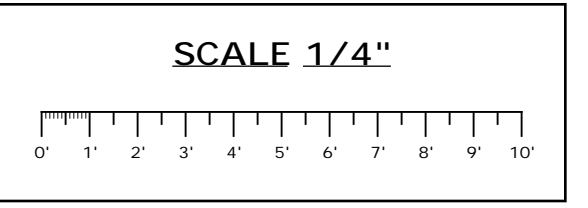
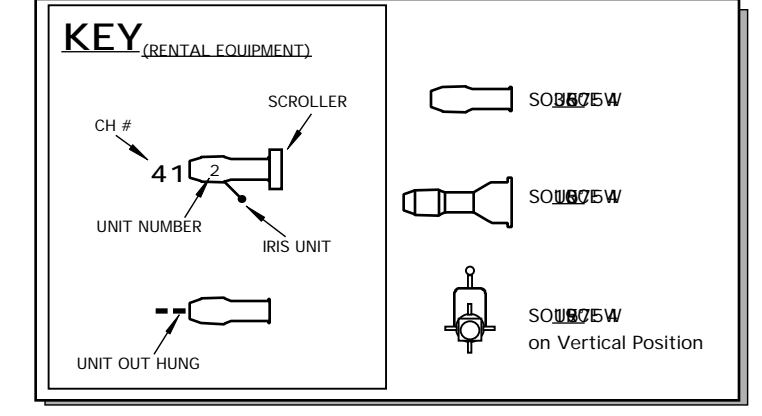

**ABBOTT LABS**  
At the C2K Theater, Las Vegas  
Producer: Katharyn Pinder / Drury Design Dynamics  
Technical Director: Katharyn A. Kephart

**ASSOCIATES**  
132 West 22nd Street  
2nd Floor  
New York, NY 10011  
Tel: (212) 414-1502  
Fax: (212) 414-1503

Scale: 1/4" = 1'-0"  
Date: 1/24/02

This drawing and all of the data, arrangements, design and plans indicated herein are created by and remain the property of Program Associates, Inc., and have been created and developed for use on and in connection with the specified project. Neither this drawing nor any of such data, arrangements, design or plans shall be appropriated by or disclosed to any person, firm or corporation for any use or purpose whatsoever, except by the specific and written permission of Program Associates, Inc.